User Manual

Product Name : HDD Mobile DVR

Product Model : WDR-4405MC(Rev.1)

Version : Rev.1



WELDEX
CORPORATION

CONTENTS

Chapter 1: Product Parameter	2
1.1 MDVR Product Specification and Parameter	2
1.2 MDVR Basic Electrical Parameter List	3
1.3 MDVR Notice	4
Chapter 2: Interace Definition and Function Description	5
2.1 MDVR Outlook and Dimension	5
2.2 HDD MDVR Panel Interface	6
2.3 Accessories	6
2.4 Installation of SIM card, SD card and hard disk.....	7
2.5 Remote Control Instruction.....	8
Chapter 3: System Menu Instruction	10
3.1 MDVR Start Up and Log In.....	10
3.2 System Setup.....	11
3.2-1 Basic Setup.....	12
3.2-2 Power Setup (see Figure 3-9).....	12
3.2-3 Password Setup (Figure 3-10).....	12
3.3 Record Setup (Figure 3-11).....	13
3.3-1 Normal Setup (Figure 3-13).....	13
3.3-2 Channel Setup (Figure 3-14).....	14
3.3-3 Schedule Setup (Figure 3-15).....	15
3.3-4 Sub-Stream (Figure 3-16).....	15
3.4 Vehicle Info.....	16
3.4-1 I/O Setup.....	16
3.4-2 G-Sensor Setup.....	17
3.4-3 Speed Setup.....	17
3.5 Tools.....	18
3.5-1 Configure Manage and Log Search.....	18
3.6 System Information.....	19
3.7 Playback.....	20
Chapter 4: Normal Settings Shortcut Control	21
4.1 Cable Connecting Test and Power On.....	21
4.2 Text Input.....	22
4.3 Recording Setup.....	23
4.4 Playback Recording on Computer.....	24
FAQ.....	27
GPS FAQ:.....	28

Chapter 1: Product Application and Parameter

1.1 MDVR Product Specification and Parameter

Specification Parameter		
System	Operation language	English
	Operation interface	Graphic operation interface(OSD menu)
	Password security	Two-level administration: user password and administrator password
Video	Video input	Support 4ch 1080P AHD video input Support 4ch 720P AHD video input Support 4ch D1 video input (recommend spec) Support 2ch 1080P AHD + 2ch 720P AHD video input Support 2ch 1080P AHD + 2ch D1 video input Support 2ch 720P AHD + 2ch D1 video input
	Video output	1ch video output(V-OUT), 1ch VGA video output
	TV system	PAL/NTSC(PAL@100 frame 1080P; NTSC@120 frame1080P)
	Image compression standard	H.264 Main profile
	Resolution	Support 1080P, 720P, D1
	Dual stream	Support
	Video display	1ch/4ch display; Supports full screen display of event triggers
Audio	Audio input	4ch audio input
	Audio output	1ch audio output(A-OUT)
	Recording method	Synchronous recording in audio&video
Image processing&storage	Local record format	1080P/720P/D1/HD1/CIF optional
	Video streaming standard	ISO14496-10
	Video bitrate	CIF: 1536Kbps ~ 128Kbps, HD1/D1: 2048Kbps ~ 400Kbps, (recommend spec) 720P : 4096Kbps ~ 1024Kbps, 1080P: 5120Kbps ~ 2048Kbps, 4 Grades optional. Highest: Grade 1; Lowest: Grade 4
	Audio bitrate	40KB/s
	Data storage	Support 1*SATA hard disk/SSD, up to 2TB; and 1*SD card, up to 256GB
	Alarm	Alarm input
Alarm output		2ch alarm output, highest output level: 12V
RS232 interface		Support
RJ45 Network interface		Support 1*6 pin aviation port to RJ45 network interface, support local network connecting with server
USB interface		Support 1*USB interface for software upgrading and record file copy
IR interface		IR extension interface,support remote control data reception
GPS system	Support build-in GPS module; geographic coordinates and speed could be written into coding streaming.	
G-sensor	Build-in G-Sensor; support triaxial motion detection and user setting of X, Y and Z coordinates	
Matching software	Playback analysis in PC	Video playback in PC, and analyze vehicle info in files
Software upgrading	Upgrading maintenance	USB upgrading, Hard disk upgrading and SD card upgrading supported
Dimension	Dimension	153.0(W) x 69.0(H) x 160.0(D) mm

2.2 MDVR Basic Electrical Parameter List

Electrical parameter		
Power input	8 ~ 36V	Power input: +8V ~ +36V; always < 8V or >36V, auto power-off will start and enter into protect mode.
Power output	12V	Power output: 12V (+/-0.2V) ; max current 2A
Operating temperature	-20℃ -60℃	Referring to excellent ventilation conditions

1.3 MDVR Notice

To ensure your MDVR's satisfactory performance and extend working life, please read and consider the following factors before installation:

1. Please comply with all electronic products standards, vehicles' and other connections' installation policy when installing your MDVR.

2. Power Supply and grounding

MDVR power supply direct input range is 8 ~ 36V DC; Please do NOT connect reversely and short circuit is not permitted for output. Please note the power supply capacity of power cable. MDVR is still charged even when it is shut down, so please be careful to avoid short circuit. Power supply must be disconnected before connecting exterior devices. MDVR output is DC 12V, only to be used for camera. Please do NOT connect other electrical equipment before consulting with a certified professional. MDVR sensor input mode is level. External voltage below 4V is low level; above 4V but lower than 30V is high level; above 30V may damage device. Correctly connect the device grounding cable to vehicle grounding cable to form a loop. If it is not in operation for long periods of time, please cut off the power supply completely to extend MDVR life.

3. Humidity Requirements

Please install your MDVR within a dry environment to avoid moist, drip or water spray; do NOT install your MDVR in sunken places where liquid may seep in or wet places where liquid may drop; Please do NOT touch your MDVR with wet hands; do NOT touch your MDVR if you are standing in water or getting into other liquids, it may cause electric shock.

4. Installation Position of the MDVR

To extend the life of the device, please install your MDVR in a place with weaker vibration, such as back of driver's seat. MDVR should be installed in a well ventilated place; it should be kept at least 6" (15cm) away from other devices on the same level for better ventilation and heat emission. MDVR can NOT be installed in enclosed spaces, such as vehicle trunk. Frontal mount or side mount is allowed.

External cables must have enough space and flame retardant protections to ensure it will not cause electrical fires due to bending or shaking abrasions. Make sure MDVR is kept away from any heat sources and the area around MDVR is cleared. Do NOT put anything on top of the MDVR.

5. Device Security

Make sure the driver and passengers can not intervene or damage any MDVR part, camera, cable or other accessories. Do NOT install MDVR beside other restricted devices of vehicle. Please keep vehicle engine turned off when installing to avoid any damage to the device.

Installation Notes:

1. MDVR contains electronic parts, please handle with care during transportation.
2. Installation and maintenance must be done by certified and trained professionals.
3. MDVR can NOT be installed in places where liquid or water erosion may occur.
4. Installation parts and accessories must be suitable to carry weight of MDVR.
5. Make sure MDVR is kept away from heat sources, dust and strong magnetic field.
6. Make sure there are no sundries on MDVR.
7. Please do NOT pour water directly onto the MDVR when cleaning the vehicle.
8. It is NOT recommended to connect other devices to MDVR power supply.
9. Please do NOT insert any objects into MDVR during its operation.
10. Please do NOT open or disassemble MDVR unless done by a trained and certified professional.
11. Replacing any module is not recommended when MDVR is working.

Chapter 2: Interface Definition and Function Description

2.1 MDVR Outlook and Dimension



Front Panel



Back Panel

Structural Dimension

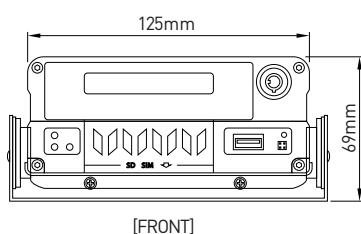

[FRONT]

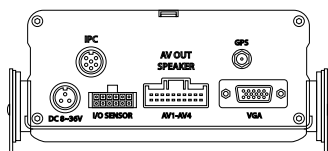

[BACK]

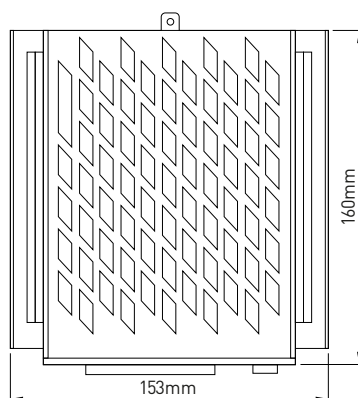

[TOP]

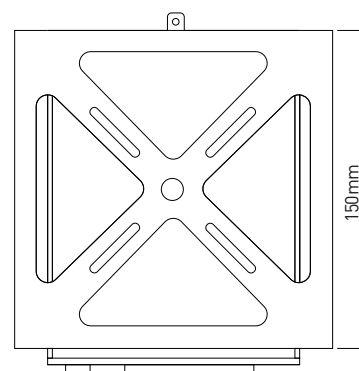

[BOTTOM]

2.2 HDD MDVR Panel Interface

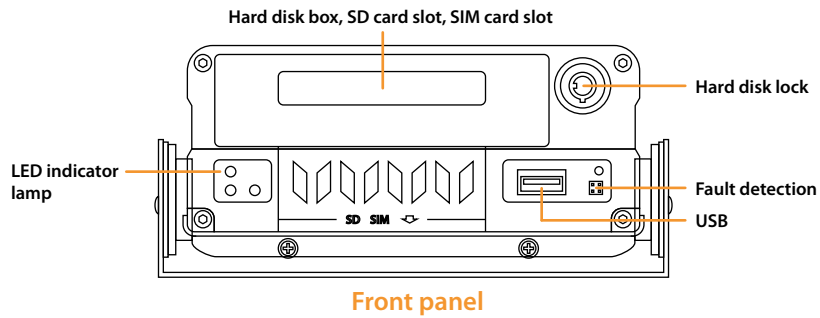

MDVR front panel specification

Hard disk box, SD card slot, SIM card slot: hard disk, SD card and SIM card slot interface.

Hard disk lock: insert key, turn clockwise, and turn off counter clockwise.

LED light: display device running status indication.

USB: used for software upgrade and video file copy.

Fault detection: device software debug interface.

2.3 Accessories

Description	Picture	Quantity(PCS)
Power cable		1
I/O cable		1
A/V cable		1
Key		2
GPS antenna(optional)		1
Remote control(optional)		1
External camera interface cable		4
External AV-out interface cable		1

2.4 Installation of SIM card, SD card and hard disk

If MDVR supports wireless network communication, it needs to install SIM card. Select the corresponding SIM card according to the wireless network supported by the device as shown in Figure 2-15.



Drive a hard disk



SD/SIM card installation

Hard disk cartridge disassembly

1、 Remove the screws on the hard disk box.



2、 Remove the SATA interface from the hard disk cartridge.

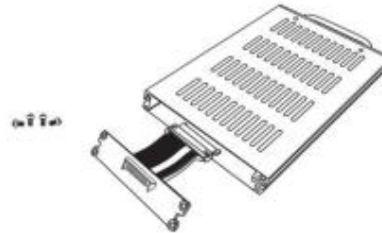

3、 Connecting SATA interface and hard disk

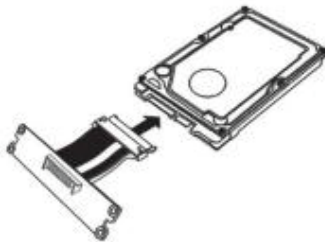

4、 Put the hard disk in the hard disk box.

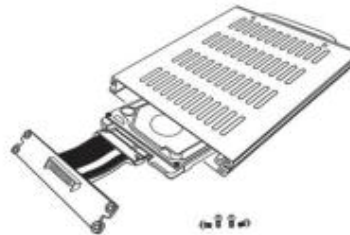

5、 Fix the hard disk on the shock proof rack with fixed

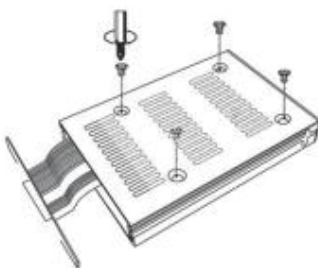

6、 Install the installed hard disk box into the host computer.

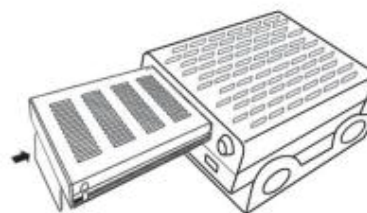

2.5 Remote Control Instruction

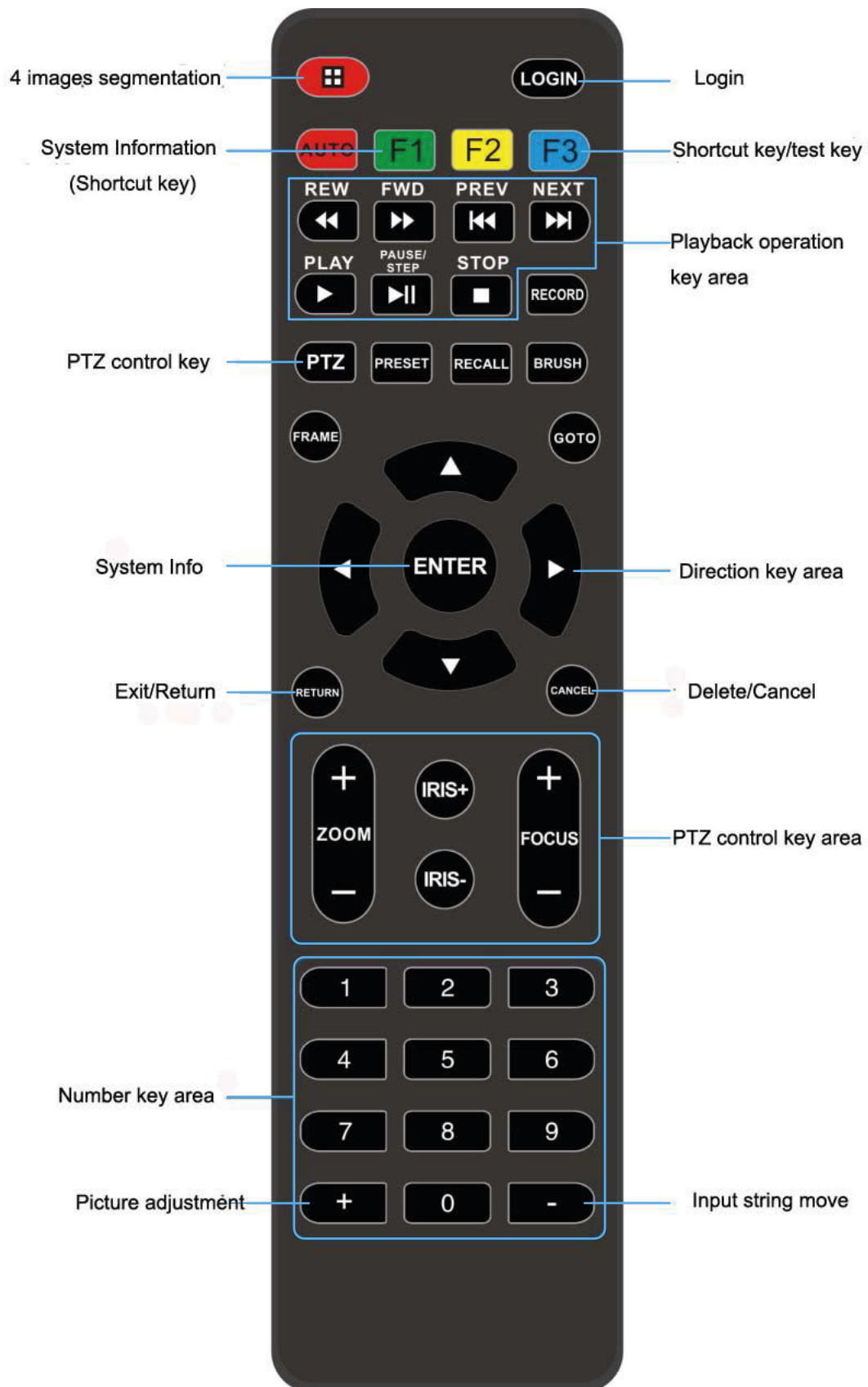

Power on / off	Press twice the MDVR will restart.(Soft start key) Note: this button has not been enabled yet
Login	This button is available if password has been set. Please keep your password in safe because MDVR has no system reset function
ENTER	Check system information
Four screen segmentation key, numeric key 1,2,3,4,5	Under the monitor screen, for switching between four pictures and one picture, press the four picture splitting keys to display four pictures on the monitor screen, press the corresponding digital key, and display the corresponding channel on the single picture: 1 - channel 1; 2 - channel 2; 3 - channel 3; 4 - channel 4; support the IPC version, digital 5 shows the IPC channel.
Return	Back to last menu until local monitoring video
Pause / Step	Pause and step forward when playback, back to normal with “Play”
GOTO	Jump to chosen point when playback
Frame	Frame playing
Play	Normal playing(Still display when pause)
Forward	Play forward when playback, four selections: 2X / 4X / 8X / 16X
Rewind	Rewind when playback, four selections: 2X / 4X / 8X / 16X
Stop Recording	Stop manual recording
Recording	Start manual recording
Next	Turn to next file / page when playback
Previous	Turn to previous file / page when playback
PTZ control	PTZ control
F1, F2, F3	F1 Version information shortcut key; F2 and F3 Standby key

Chapter 3: System Menu Instruction

3.1 MDVR Start Up and Log In

Turn on MDVR after power supply and other accessories has been correctly assembled and carefully inspected. Figure 3-1 is system loading picture; Figure 3-2 is the areas monitored by camera.

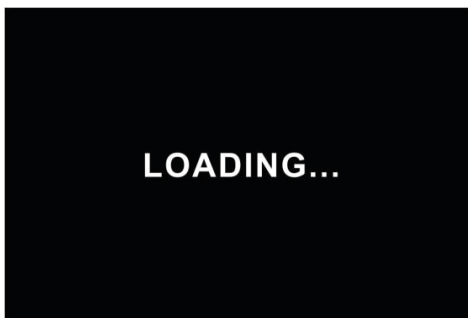

Figure 3-1



Figure3-2

Press “LOGIN” on the remote control ,like Figure 3-3 to enter system menu, see Figure 3-4.

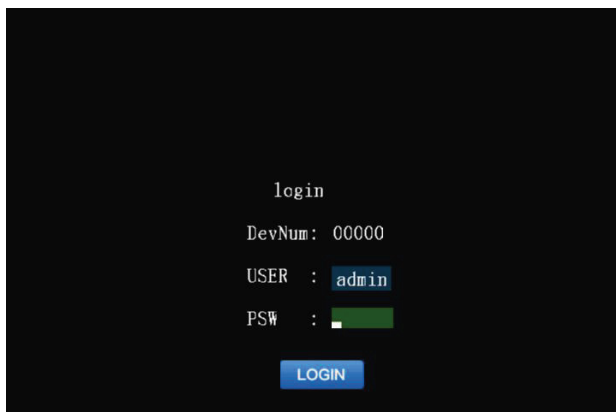

Figure 3-3

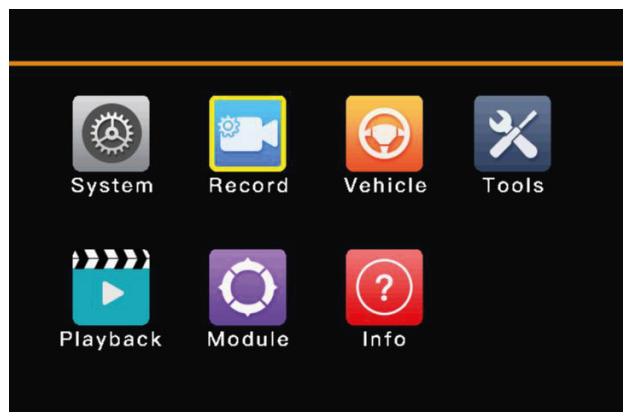

Figure 3-4

INSTRUCTION:

DEV NUM: MDVR serial number, user can define it. The number will be shown on the right of login menu, please input as the number shown below. The number must be unique in one server. Please check 3.3 for number setting.

USER: User name, including “Admin” and normal “User”. Normal user can not change the settings, they only can access log search and playback video recording, check system information etc. Only the administrator can change all settings.

PSW: Password. Input password against user name, and then login system. Use “Cancel” to delete and re-input if you have entered wrong password. The default “User” password is 000000, and the default “admin” password is 111111.

System menu contains seven main menu options: SYSTEM, RECORD, VEHICLE, TOOLS, PLAYBACK, MODULE AND INFO, see Figure 3-4.

CAUTION:

1. All Sub-menu setting must be saved after it has been changed; otherwise, the new settings will be invalid.
2. Function is selected with check box filled, otherwise, it is not.
3. Input numbers with number keys on the remote control or soft keyboard. Input letters only can with the soft keyboard. You can go back to the main menu with the “RETURN” key.

3.2: System Setup

System Setup is the first menu option of main menu. Include three items: BASIC, POWER and PASSWORD. see Figure 3-6 and Figure 3-7.

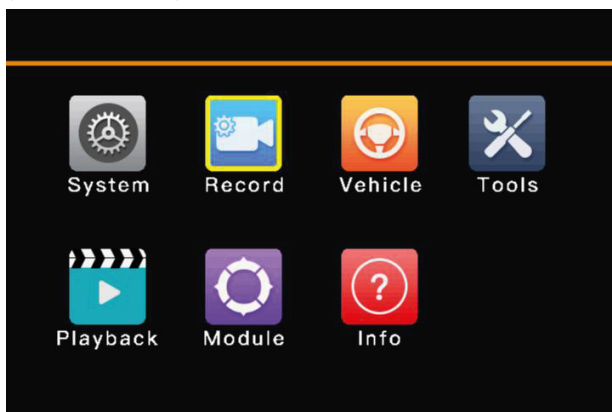

Figure 3-6

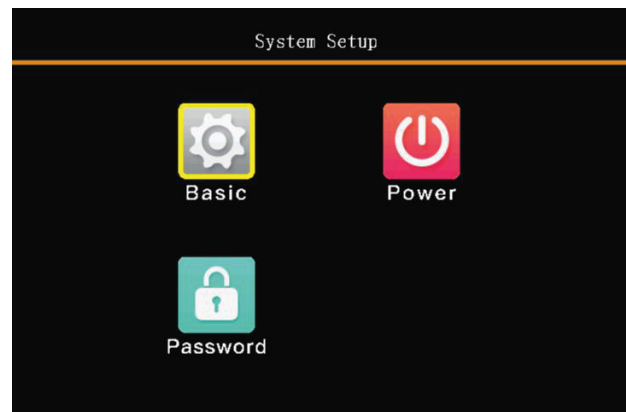

Figure 3-7

3.2-1 Basic Setup

Setting system time and some other basic parameters, see Figure 3-8.

1. DATE TYPE: press “ENTER” to switch time displaying format between Y-M-D and D-M-Y.
2. DATE / TIME: remove cursor to locate, then press “ENTER” to choose and press “+” or “-“ to set, at last press “ENTER” again to confirm.

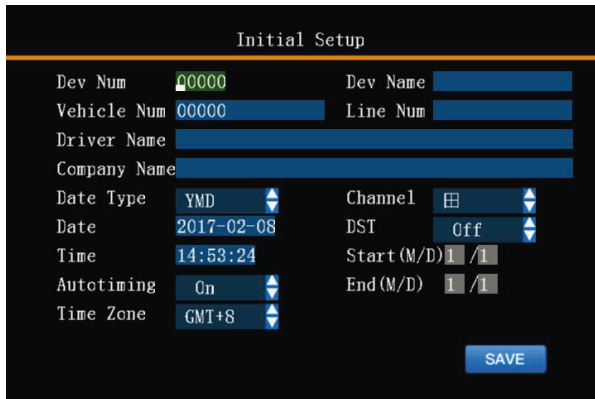

Figure 3-8

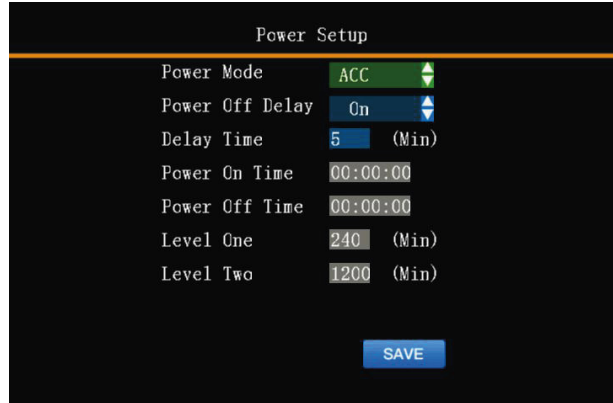

Figure 3-9

3. COMPANY NAME / VEHICLE NUM / DRIVER NAME / LINE NUM: press “ENTER” to pop out soft keyboard, then use arrow button and “ENTER” to set
4. AUTO TIMING: if this function is turned on, MDVR will automatically update the time via GPS depending on where the vehicle is located.
5. Channel: there are "QUAD" and "single channel" two choices, "QUAD" is the normal boot after the monitoring of the four screen, if the choice of "single channel" that is CH1 / CH2 / CH3 / CH4, is to monitor the corresponding channel screen.

3.2-2 Power Set (see Figure 3-9)

1. POWER MODE: Three options – TIME, ACC and Delay mode.
TIME: MDVR turns on as it is set by the user (POWER ON TIME / POWER OFF TIME);
ACC: This is the default setting; MDVR turns on when the vehicle engine starts;
2. POWER OFF DELAY: delay time range is 3-240mins. MDVR will keep working after vehicle engine turned off if this set in “ON”.

3.2-3 Password Setup (Figure 3-10)

1. Password can be switched “ON” or “OFF”.
2. Only Administrator can modify password. Default admin password is “111111”; Default user password is “000000”;

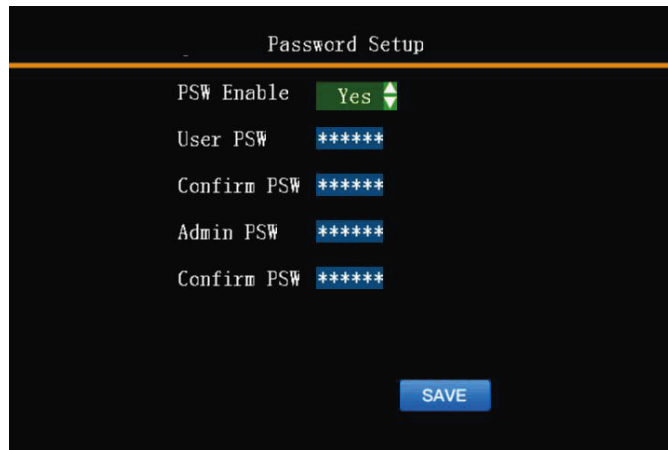

Figure 3-10

3.3 Record Setup (Figure 3-11)

Four sub menus: NORMAL, CHANNEL, SCHEDULE and SUB-STREAM. MDVR will start recording once power is on. User can define recording mode as their requirement.

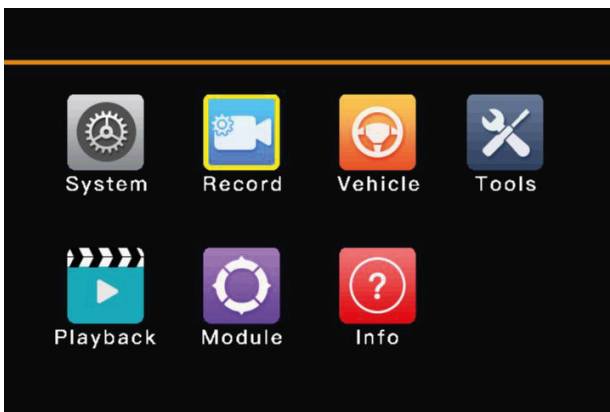

Figure 3-11

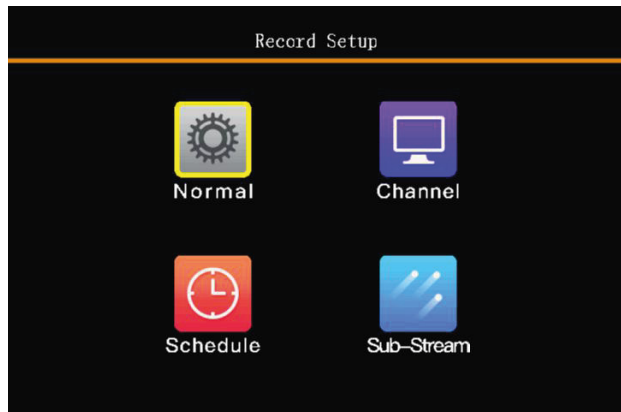

Figure 3-12

3.3-1 Normal Setup (Figure 3-13)

1. SYSTEM: PAL or NTSC.
2. REC MODE: three options – AUTO / ALARM / TIME.
3. PACKET TIME: recording packing time, four options – 15 / 30 / 45 / 60mins.
4. OVERWRITTEN: MDVR will overwrite previous recording after HDD is full with “ON”, otherwise, it will not.
5. VOLUME OUT: 1 – 15 levels.
6. ALM PRE-REC TIME / ALM REC DELAY: pre-recording time (0 – 60s) before alarm happens and delay recording time (30 - 900s) after alarm is over.
7. ALM OUTPUT TIME: extended alarm device working time (5 – 240s).
8. REC PROTECT TIME: alarm recording saving time. Alarm recording will not be overwritten in the time even the HDD is full. Six options – 1 / 3 / 5 / 7 / 10 / 15 days.
9. REC VEHICLE INFO: two options – ON / OFF. “ON” means MDVR will save the alarm and GPS information when recording. User can check the information by playback.

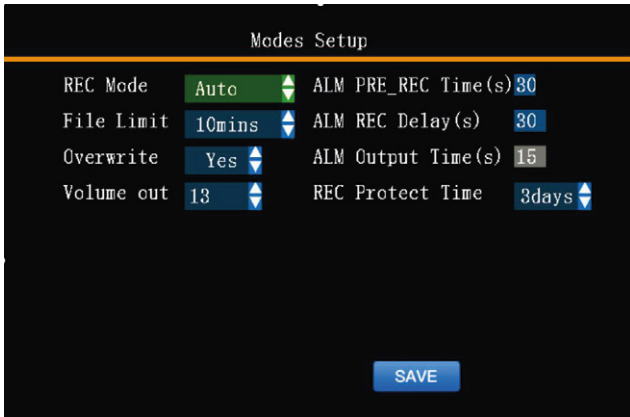
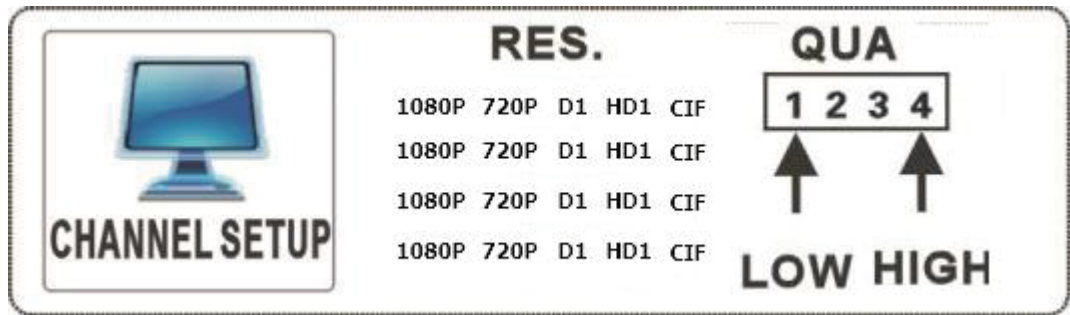

Figure 3-13



Figure 3-14

3.3-2 Channel Setup (Figure 3-14)



Define settings for each channel, such as RES (resolution), FPS (frame per second), QUAL (video quality) etc.

REC (resolution): 1080P/720P/D1 / HD1 / CIF.

FPS (frame per second): 1 – 30 fps level settings (30 is real time).

QUAL (video quality): 1 – 4 quality level settings, 4 is the best, 1 is the worst, default is 3. Switch “ENABLE” to “OFF” to turn off any channel if you don't need it.

MIC: MDVR will record audio with “ON” – camera must have an internal microphone or have an external audio recording device connected.

3.3-3 Schedule Setup (Figure 3-15)

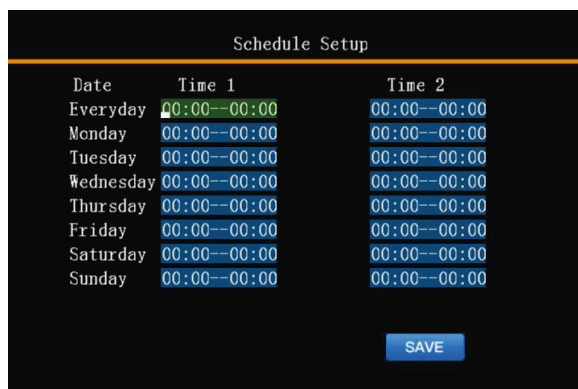
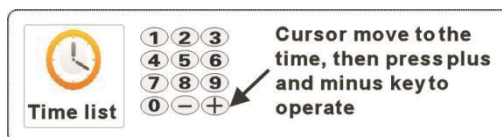

Figure 3-15



The user can set recording schedule here when recording mode is “TIME”.
Remove cursor to set the time with “+” or “-“keys.

3.3-4 Sub-Stream (Figure 3-16)

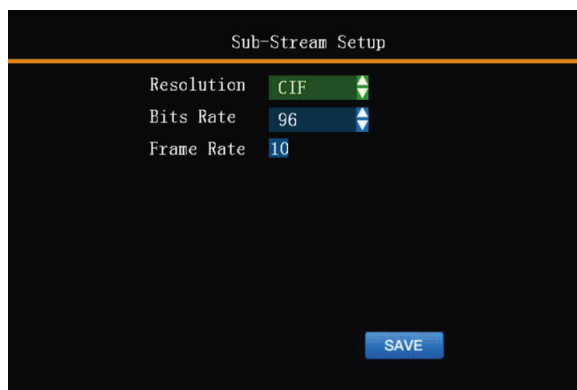

Figure 3-16

Sub-stream parameters will impact video definition and connection between MDVR and CMS, of course, the main determinant of video quality and network transmission fluent is local network condition.

RESOLUTION: two options – CIF / QCIF.

BITS RATE & FRAME RATE: single channel bit rate and frame rate, the default bit rate is 96bps, and the default frame rate is 10fps. Users can define setting here base on local network condition. Please check the table below for the detailed rate settings between bit and frame.

	BITS RATE:	16	24	32	40	48	56	64	72	80	96	128	160	200	256	384	Auto
	SUB-STREAM FRAME RATE:	01	---	---	02	---	03	04	05	07	10	13	15	20	23	25	25

3.4 Vehicle Info

Include Three sub menus: I/O, SPEED and G-SENSOR.

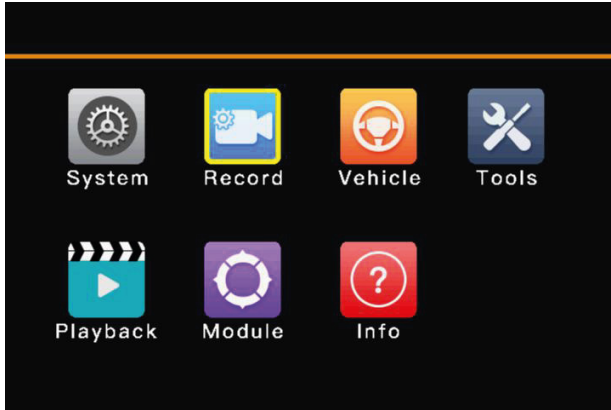

Figure 3-17

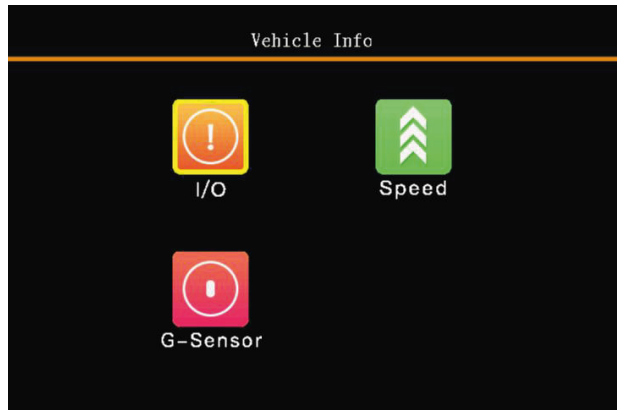

Figure 3-18

3.4-1 I/O Setup



Figure 3-19

Define alarm input here. User can assign names to each sensor to suit their specifications, such as “front door”, “back door” or “brake” etc.

“ENABLE” is sensor ON or OFF. User can set recording mode as “ALARM”, and then determine recording and alarm should be open or not. As users’ setting, high / low level may trigger alarm, usually, users will use high level(>5V) to trigger alarm, see diagram as figure 2-13.

3.4-2 G-Sensor Setup



Figure 3-20

X / Y / Z shows three axes of vehicle – top and bottom, left and right, front and back. G-senor will detect vehicle condition, if condition changes cross over defined parameters, MDVR will record and trigger alarm as per users' setting. Defined parameter can be tested, please check chapter 4.3 Part 3 for more details.

“ADJUST” is to clear previous setting and return to zero. Please check and clear to back to zero before new setting.

3.4-3 Speed Setup



Figure 3-21

SPD SOURCE: two options - GPS / VEHICLE, press “ENTER” to switch.

1. If your MDVR contains the GPS option, select “GPS”, MDVR will detect the vehicle speed automatically and relays the information to control center via 3G network.
2. If selecting “VEHICLE”, MDVR requires an external pulse sensor to measure vehicle speed ratio (coefficient=pulse / speed). Pulse sensor connects to SPEED-A and SPEED-B. Speed ratio will be calculated by defined speed and captured pulse.
3. SPD UNIT can be switched between “KM” and “MPH”. The “LOW SPD” and “HIGH” can be enabled as user setting, speed limitation as “THRESHOLD”. Alarm recording will be executed if it is “ON”(recording mode must be “Alarm”).

3.5 Tools



Figure 3-22

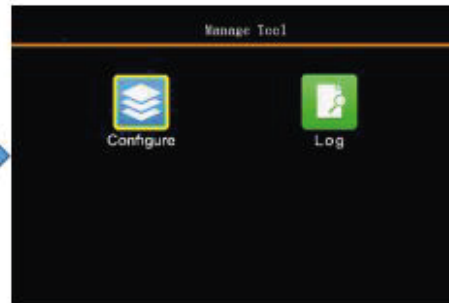

Figure 3-23

Four sub menus: CONFIGURE, LOG, DETECTION, ..

3.5-1 Configure Manual Manage and Log Search

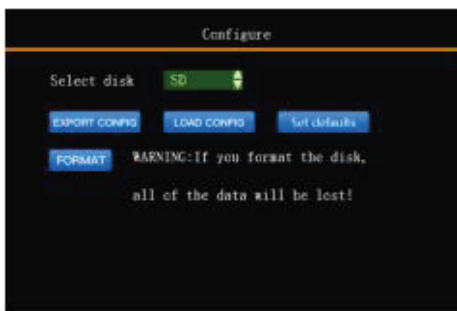

Figure 3-24

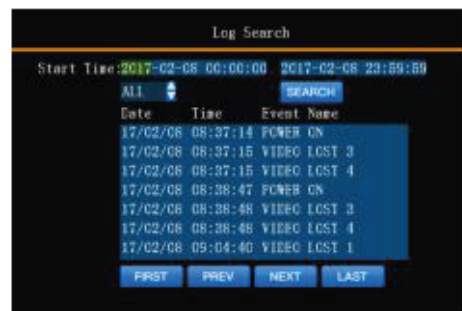

Figure 3-25



User can utilize three functions under configure manage – export configure, load new configure and reset setting, and format the HDD or SD card.

Export configure: MDVR will save the user's setting as a file in HDD.

Load new configure: MDVR will load the user's setting from a file.

Reset Setting: MDVR will go back to factory default setting.

Please format HDD before the first use in your MDVR.

Note: all saved information will be deleted while formatting, please make sure all useful information have been backed up and removed before formatting.



Back to factory default setting may be helpful when some unconventional issues happen on your MDVR.

MDVR will save all the system's information automatically, such as system power on, user login, user setting, network setting, video loss, video playback, motion detection etc. Input "START TIME" and "END TIME", then select search type (ALL / ALARM / USER) to search.

3.6 System Information

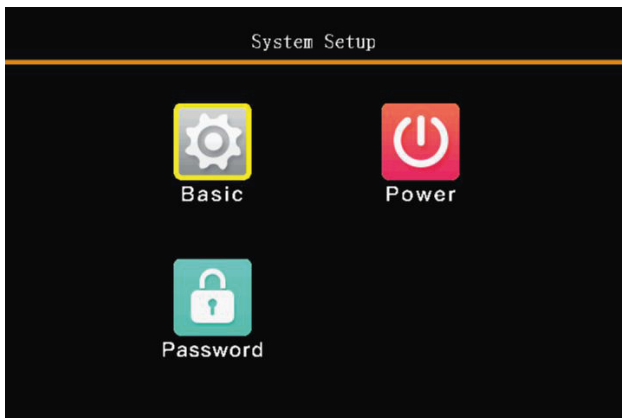

Figure 3-35

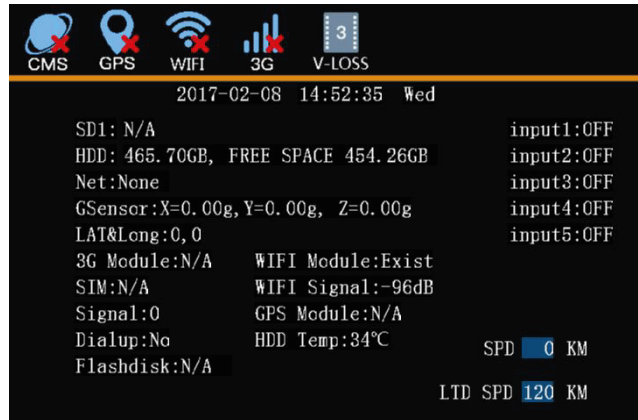

Figure 3-36

Enter "Enter" from main menu; MDVR will appear system information like Figure 3-35 (press F1 from remote control under 4CH local view can enter the sub menu). User can check firmware, hardware, MCU information and HDD status. Press "ENTER" to enter other information

3.7 Playback

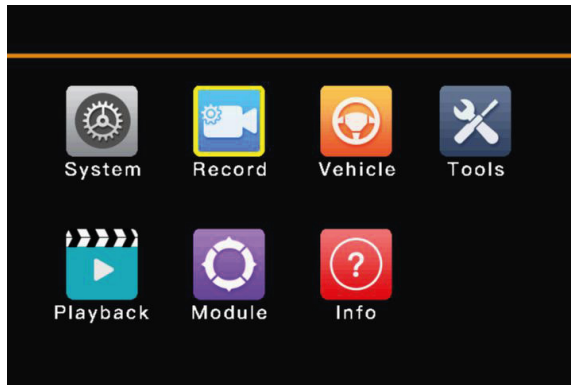

Figure 3-37

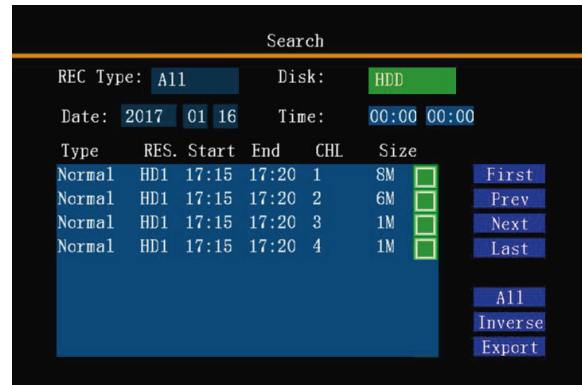

Figure 3-38

A: SEARCH INSTRUCTION

Enter “PLAYBACK” menu, then search record as per different record type and HDD/SD1/ to play back record. Support time and date search, the green cell means record is alive.

REC TYPE: ALL and ALARM optional;

CHANNEL: HDD item number;

DATE: search as defined date;

START TIME / END TIME: search as defined time;

B: SEARCH RESULT

Search result is shown in Figure 3-38.

TYPE: recording type, normal or alarm. Normal contains power on recording and timed recording;

Alarm is alarm recording. Only when alarm has been set and external alarm device is connected, MDVR will record alarm video, such as alarm sensor, over speed, motion detection etc.

RES.: recording resolution, Five formats: 1080P/720P/D1 / HD1 / CIF.

START / END: recording beginning time and ending time.

CHL: recording channel.

SIZE: recording file size, decided by resolution and recording file packing time.

C: PLAYBACK



Figure 3-39

Select one file from search result – the yellow line indicates the selected file, press “ENTER” to play the selected file. Playback interface is just like Figure 3-39. User can check recording time, vehicle speed, GPS information etc. from playback window.

Please check remote control instruction for playback shortcut button.

MDVR only supports one channel audio out one time. Please select a channel and use left/right arrow button to adjust volume.

Chapter 4: Normal Settings Shortcut Control

4.1 Cable Connecting Test and Power On

The MDVR has three color coded power cables– red, yellow and black. The red cable connects to anode of vehicle battery; the black one connects to cathode; the yellow one connects to vehicle ignition wire. When testing DVR out of vehicle; the power supply cable should be modified – combine red and yellow cable in one to connect to anode; black cable connects to cathode, use DC12V / 5A to offer power to MDVR.

1. After power supply cable has been connected correctly, the blue indicator light – PWR will light up.
2. Connect AV-out cable to monitor and connect other external devices to MDVR, make sure connection is right.
3. Electronic lock must be in the “LOCK” position then MDVR can power on normally.

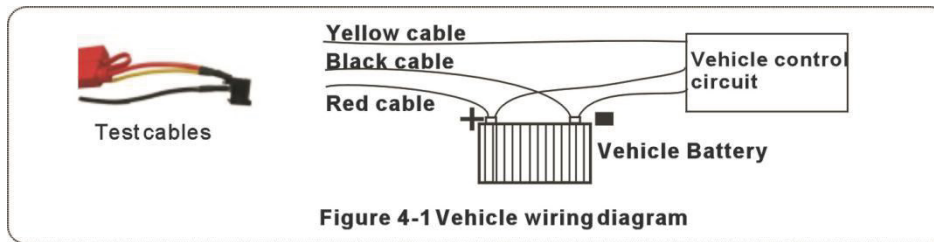



Figure 4-1 shows the testing cables connection and actual cable connection.

CAUTION:

1. Power voltage input range is DC 8~36V. If only one red indicator light lights up, that means MDVR is in standby; more lamps should be lights up if MDVR is working.
2. If charge MDVR with testing cable, the device can not delay power off.

4.2 Text Input

Continue the 3.3-1 section to input the text,include the Company name,vehicle number,driver name and line number and the other menu which need to input the text.Enter the input screen,Take the 粤 B95886 for example to explain how to input:

1. In Chinese Input, see Figure 4-2,the spell of “粤”is“yue”,move the cursor and press“ENTER”to input the first letter “Y”,If there is no option on the first 1-5, enter the FWD on the remote controller to turn the page till find the right spell and choose the Corresponding figures, then if no “粤”this word, use the FWD to turn page,till find the right word you want.
2. For the letter “B”,move the cursor to the  and then press “ENTER” to change the input to EN,see Figure 4-3,move the cursor to letter “B”,press the “ENTER” to input.
3. For the number,press the  again,back to Chinese Input,in this input, we can't enter the number, need to move the cursor to this word: “中”, press “ENTER”and will change to “EN”, then put the number 95668.

After we finish the above, press the“RETURN”and save it.The other menu which need to input the text are the same, If there is any input error, enter the “CANCEL” to delete it,the “SPACE”key is on the left side of .



Figure 4-2



Figure 4-3

4.3 Recording Setup

1. AUTO RECORDING

With factory default setting, MDVR will record automatically after power on.

NOTE: please format HDD/SD card, if it is used for the first time.

2. TIME RECORDING

Set time recording as per below menu path:

MENU – RECORD SETUP – NORMAL SETUP – REC MODE

Set REC MODE as “TIME”, and then go back to previous menu to set recording time. Please check chapter 3.4-3 for menu setting.

1. ALARM RECORDING

Set alarm recording as per below menu path:

MENU – RECORD SETUP – NORMAL SETUP – REC MODE

Set REC MODE as “ALARM”, and then set pre-recording time (0-60s), delay recording time (30-900s) and alarm output time (5-240s).

MDVR needs to be connected to the vehicle’s input devices, such as emergency button, door control, hard braking and other sensors. Your MDVR supports below alarm types:

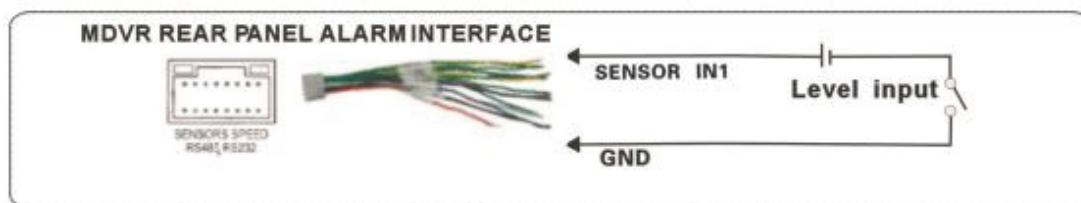

Figure 4-4

A: SENSOR INPUT ALARM

Set as per below path: MENU – VEHICLE INFO – SENSOR SETUP

Set high / low level trigger in Figure 3-19, and then turn on recording.

This menu supports three vehicle sensor input on your MDVR, such as door control, hard braking, emergency button, and other sensors etc. See cable connection shown in Figure 4-2.

B: OVERSPEED ALARM

Set as per below path: MENU – VEHICLE INFO – SPEED SETUP

MDVR captures vehicle speed through GPS, see Figure 3-21, recording will be turned on and speed limitation has been set, for example: if the vehicle speed limiter is set for 100KM/H, the MDVR will simultaneously trigger the alarm and recording if the vehicle goes over 100KM/H.

If MDVR captures speed through vehicle, an external speed impulse sensor will be needed. The sensor is connected to SPEED-A and SPEED-B, it will measure the defined speed and captured pulse to get speed ratio (ratio = pulse / speed). This will be a little bit complex. Cable connection is as shown below Figure 4-5.

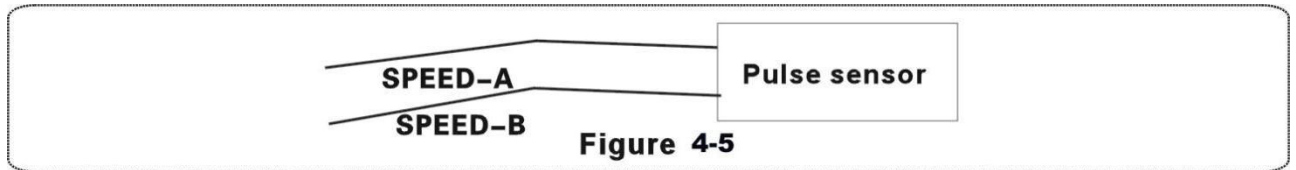

C: G-SENSOR ALARM RECORDING

Set as per below path: MENU – VEHICLE INFO – G-SENSOR

See Figure 3-20, G-SENSOR is an X / Y / Z coordinate axis, three vehicle axes will be appeared: top and down, left and right, front and back. Any changes while the vehicle running, such as wallowing, speeding, braking or turning etc., will be appeared on the coordinate axis. This gives the MDVR a limitation number, then clear first number back to zero. While the vehicle is running, status will be appeared on the coordinate axis, if it is over than limited number, then alarm will be triggered and video will be recorded.

D: MOTION DETECTION

Set as per below path: MENU – TOOL – MOTION DETECTION

See Figure 3-26, turn on motion detection and set detection level – high, middle or low. Next step is to set detection area, see Figure 3-27. Recording will be triggered by motion.

4.4 Playback Recordings on Computer

Recording can be played on MDVR or copy to computer to play with a special MDVR player.

Player installation:

User can find player installation program in attached CD. Run this program, select displaying language and then press “NEXT” to complete installation. See Figure 4-8.



Remove the HDD/SD card from MDVR and connect to computer. After driver installed, HDD/SD card will be open automatically (or user can open it from “My computer”). Recording files are saved in different files which are named by date, see Figure 4-9.

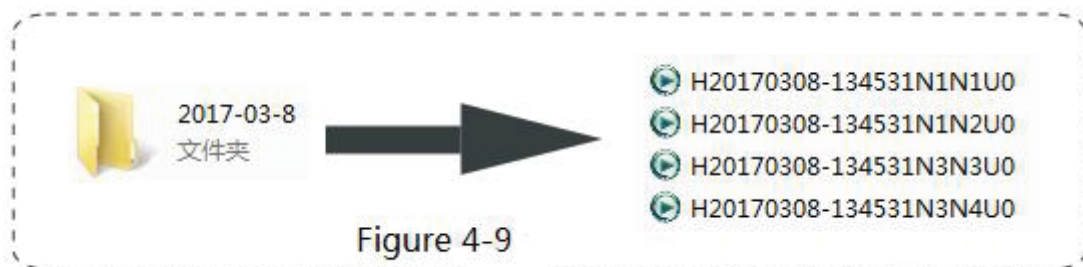
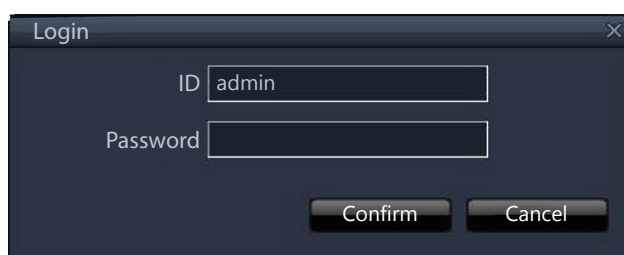

Figure 4-9

Double click to login the playback software, the account is "admin" with password 888888, the playback interface is shown as Figure 4-10.



video playback zone

vehicle tracking zone

status display area

Speed analyses

file list

alarm list

log list

Function zone

Open: Click to open the record file on the computer.

System set: Set the player, include: Language, Map, video parameter set, see below picture:

System Setup

System Parameters

Language: English Windows: Four Windows

Login Setting: Need user name and Player view scale: 16:9

User Management Clear Password

Window Param

Show date window Speed Unit: km/h

Map Parameters

GPS Offset Corre Show GPS Track

Map Type: Google

Video Parameters

Watermark Verify Use RGB16

Water Mask: 0 AutoPlay

Show Channel Number

Horizontal: 20 Pixels Vertical: 10 Pixels

Overlay I/O Alarm Information

Position: Top

Horizontal: 60 Pixels Vertical: 70 Pixels

Overlay ACC And Winker

Position: Top

Horizontal: 60 Pixels Vertical: 70 Pixels

Overlay Driver And Company

Position: Top

Horizontal: 60 Pixels Vertical: 70 Pixels

Overlay Device And Camera Name

Position: Top

Horizontal: 60 Pixels Vertical: 90 Pixels

File Associations

.AVI File .264 File

OK Cancel

FAQ

Q1: What should user do if they can not fix by themselves when MDVR issue happens?

A1: User can inspect device firstly and check cable connection or parameter setting. If user can not fix issues by themselves, please contact supplier for technical support by providing them device model no. and firmware no.;

Q2: What should user do if there is no video output on monitor?

A2: 1. Check MDVR status. If MDVR is in standby, it will not transfer any video out. Meanwhile, check power supply cable; make sure the red and yellow cable is charging, MDVR will not work properly with only one cable charging.

2. Check monitor, make sure monitor is working well in AV mode.

3. Check the cable connection between monitor and MDVR video output.

4. Check whether MDVR electronic lock is in the "LOCK" position, MDVR will not work normally if it is not in the "LOCK" position.

Q3: What should user do if camera output connector is different from the MDVR input connector?

A3: MDVR is with aviation port. Please add an adapter to connect if connectors are different. Or users may refer to interface definition.

Q4: What can user do if MDVR does not record after powering on?

A4: 1. Check HDD and SD card(including slot) status, make sure they are in good working condition.

2. If it is a new HDD and the first time to use, please initialize in computer and then install in MDVR. Enter MENU – TOOL – FORMAT to format HDD.

3. Check recording setting; make sure recording channel has been turned on. If schedule setup is open, MDVR won't record without scheduled time.

4. Check if REC Mode is Alarm; in this setting, MDVR will only record when alarms occur. Default setting is Auto.

5. Check if ever remove SD card when MDVR still working. Please remove SD card when power off.

Q5: What should user do if recording file lost or no recording file in a certain period time?

A5: 1. Try to play recording before that time and after that time, make sure recording file is workable.

2. Check MDVR log to make sure MDVR is working in that time. MDVR will not work if REC Delay not open when vehicle stops temporarily.

Q6: What should user do if user can not control PTZ?

A6: Check PTZ setting, make sure all settings(e.g.: protocol, baud rate,address code) are consistent with PTZ camera. When use PTZ, please maximize the channel you select; e.g.: if you choose Ch2, Ch2 must be maximized.

GPS FAQ

Q1: What should user do if GPS exists but has no coordinate?

A1: 1. Check MDVR system information to make sure GPS module exists. If GPS module not exists, please check connectors to see if all well connected.

2. Inspect GPS antenna and move it to another place with stronger signal to have a try. Please note: some vehicle glass shielding film may obstruct GPS signal.

3. If GPS antenna is in house for testing and signal is obstructed, please take it outside for a try.

Q2: What can user do if geographical information is incorrect?

A2: If GPS module has been located means signal is valid. There are several possible reasons which may bring this problem: government limitation, tolerance, GPS signal break off etc. For safety's sake, the satellite map has deviation. User can have a try with GPS calibration in general map.